

Rocker Inner Panel Reinforcement Replacement

Removal Procedure

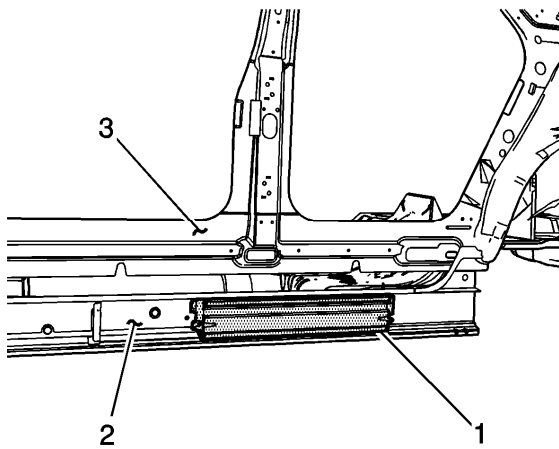

Caution: Refer to [Approved Equipment for Collision Repair Caution](#) in Cautions and Notices.

Important: A structural reinforcement (1) is located between the inner rocker (2) and the inner body side panel (3) on both the right and the left side of the vehicle. Aluminum replacements are available if necessary, and can be ordered separately.

Failure to replace any damaged reinforcement as described could compromise the structural integrity of the vehicle.

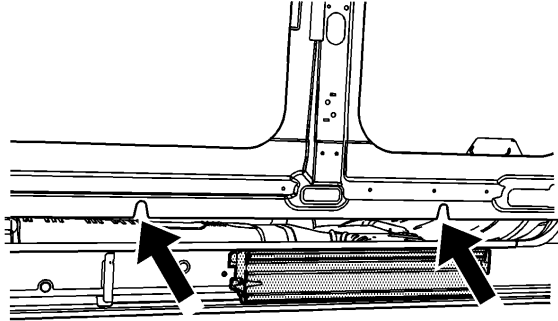

1. Remove the inner front door lock pillar. Refer to [Body Lock Pillar Inner Panel Sectioning Replacement](#) .

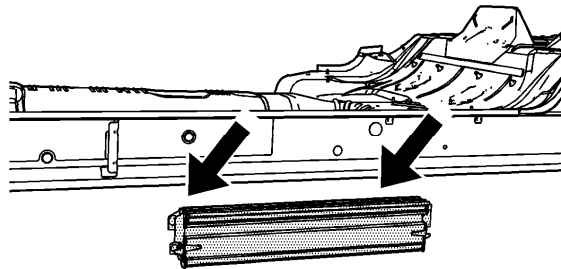

2. Remove the damaged structural reinforcement.

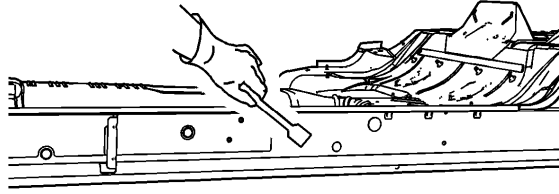

Important: Do NOT remove existing primer from the inner panels when removing the structural reinforcement.

3. If the inner rocker panel is not being replaced, use a chisel or equivalent to remove the excess and loose structural adhesive from the inner rocker panel.

Installation Procedure

Important: Use only enough naphtha solvent to dampen a cloth. Too much solvent may saturate the structural reinforcement and may migrate out later, affecting the bond strength of the adhesive.

1. Clean the replacement structural reinforcement and all of the mating surfaces with naphtha solvent. Allow to dry thoroughly.

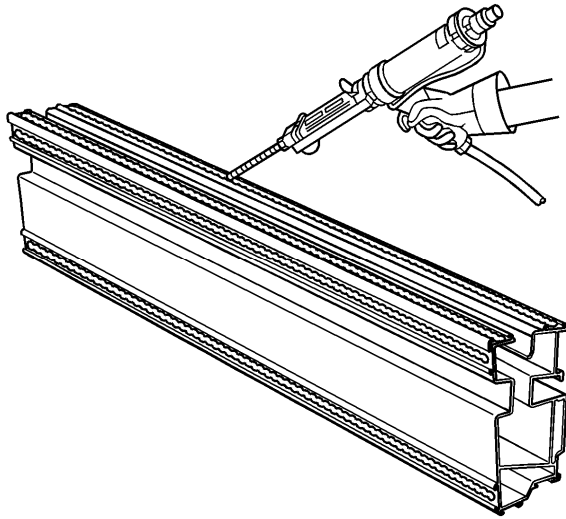

Important: The adhesive has a 40-50 minute work time. Do NOT allow the adhesive to cure prior to installing the structural reinforcement to the vehicle and to the inner hinge pillar reinforcement.

2. Apply six 9-13 mm beads of Fusor 120 adhesive GM P/N 12345726 to the reinforcement mating surface.

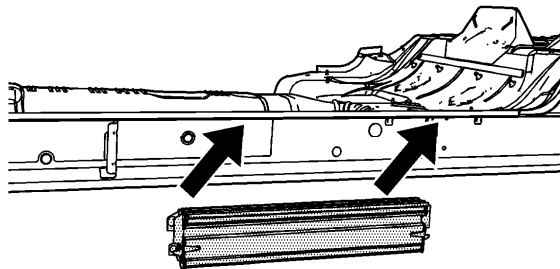

Important: Do NOT pull the structural reinforcement apart from the adjacent panels after the panels have been joined together. Slide the reinforcements from side to side, or up and down, for proper alignment.

3. Position the structural reinforcement to the body and push firmly into place.

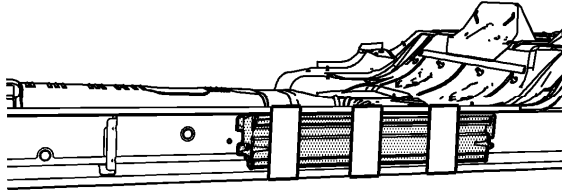

4. Temporarily hold the structural reinforcement in place with tape.
5. Remove the tape from the structural reinforcement.

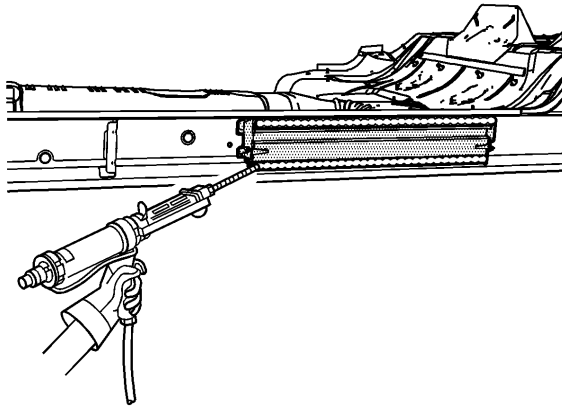

6. Apply 9-13 mm beads of Fusor 120 adhesive GM P/N 12345726 (Canadian P/N 10953521) to the reinforcement mating surface of the inner body side, as shown.

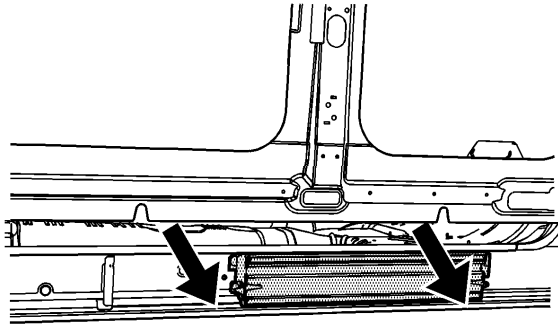

Important: Do NOT pull the outer body side assembly apart from the structural reinforcement after the parts have been joined together. Slide the outer panel from side to side, or up and down, for proper alignment.

7. Position the body side inner assembly and clamp into place. Refer to [Body Lock Pillar Inner Panel Sectioning Replacement](#) .