

Rocker Inner Panel Replacement

Removal Procedure

Caution: Refer to [Approved Equipment for Collision Repair Caution](#) in Cautions and Notices.

1. Disable the SIR system. Refer to [SIR Disabling and Enabling](#) .
2. Disconnect the negative battery cable. Refer to [Battery Negative Cable Disconnection and Connection](#) .
3. Remove all related panels and components.
4. Repair as much of the damaged area as possible. Refer to [Dimensions - Body](#) .

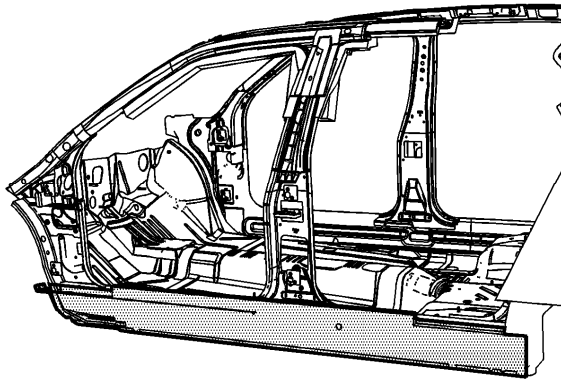

5. Remove the sealers and anti-corrosion materials from the repair area, as necessary. Refer to [Anti-Corrosion Treatment and Repair](#) .

Important: Structural foam is located between the inner rocker and the inner body side on both the right and the left side of the vehicle. Precast structural foam replacement blocks are available, if necessary, and may be ordered separately.

Failure to replace any damaged structural foam reinforcement as described could compromise the structural integrity of the vehicle. Refer to [Structure Foam Replacement](#) .

Important: Note the number and location of the factory welds for installation of the inner rocker panel.

6. Locate and drill out all the necessary factory welds.

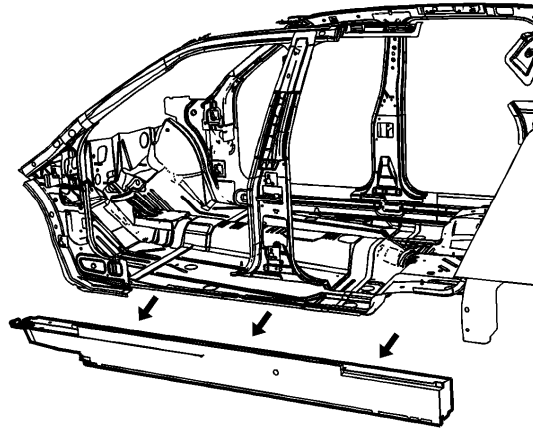

7. Remove the inner rocker panel.

Installation Procedure

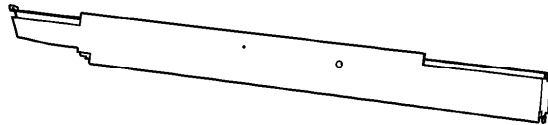

Important: If the location of the original plug weld holes cannot be determined, space the plug weld holes every 40 mm (1½ in) apart.

1. Drill 8 mm (5/16 in) plug weld holes in the service part, as necessary in the locations noted from the original panel.
2. Prepare all mating surfaces, as necessary.

3. Apply GM-approved Weld-Thru Coating or equivalent to all mating surfaces. Refer to [Anti-Corrosion Treatment and Repair](#) .

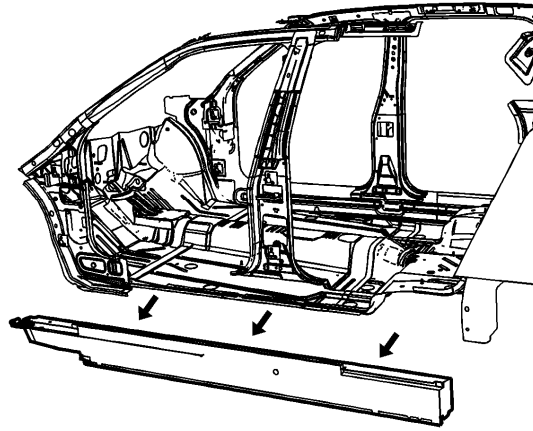

4. Position the inner rocker panel and clamp the panel in place.

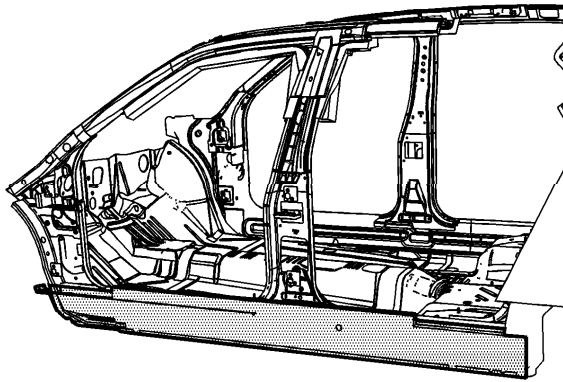

5. Plug weld accordingly.
6. Clean and prepare all of the welded surfaces.
7. Install all of the related panels and components.
8. Apply the sealers and anti-corrosion materials to the repair area, as necessary. Refer to [Anti-Corrosion Treatment and Repair](#) .
9. Paint the repaired area. Refer to [Basecoat/Clearcoat Paint Systems](#) .
10. Connect the negative battery cable. Refer to [Battery Negative Cable Disconnection and Connection](#) .
11. Enable the SIR system. Refer to [SIR Disabling and Enabling](#) .