

2. Radiator Support Assembly

The radiator support assembly consists of twelve major components: nine upper panels, and three lower panels (figure 2-1). In addition, there are four headlight mounting brackets.

Upper Radiator Support Components

There are two service assemblies, each made up from three of the nine upper panels (figure 2-1). There are no factory welds along the rear edge of these assemblies. The rear edge of these assemblies sandwich the front edge of the wheelhouse apron. After positioning the rest of the radiator support components, check the fit using three dimensional measuring equipment. Plug weld all the panels accordingly, including the rear edge of the assemblies to the wheelhouse apron.

Lower Radiator Support Components

The lower three panels, also called the lower tie-bar, are welded to the lower rails. The three lower panels are available and serviced separately (figure 2-1).

Headlight Mounting Components

There are two mounting brackets for each headlight assembly. One mounts to the side of the wheelhouse apron and upper rail assembly. The other bracket mounts to the front upper radiator support and the top of the lower rail (figure 2-1). The service part headlight mounting holes are pre-drilled and will need to be located and shimmed accordingly, using three dimensional measuring equipment.

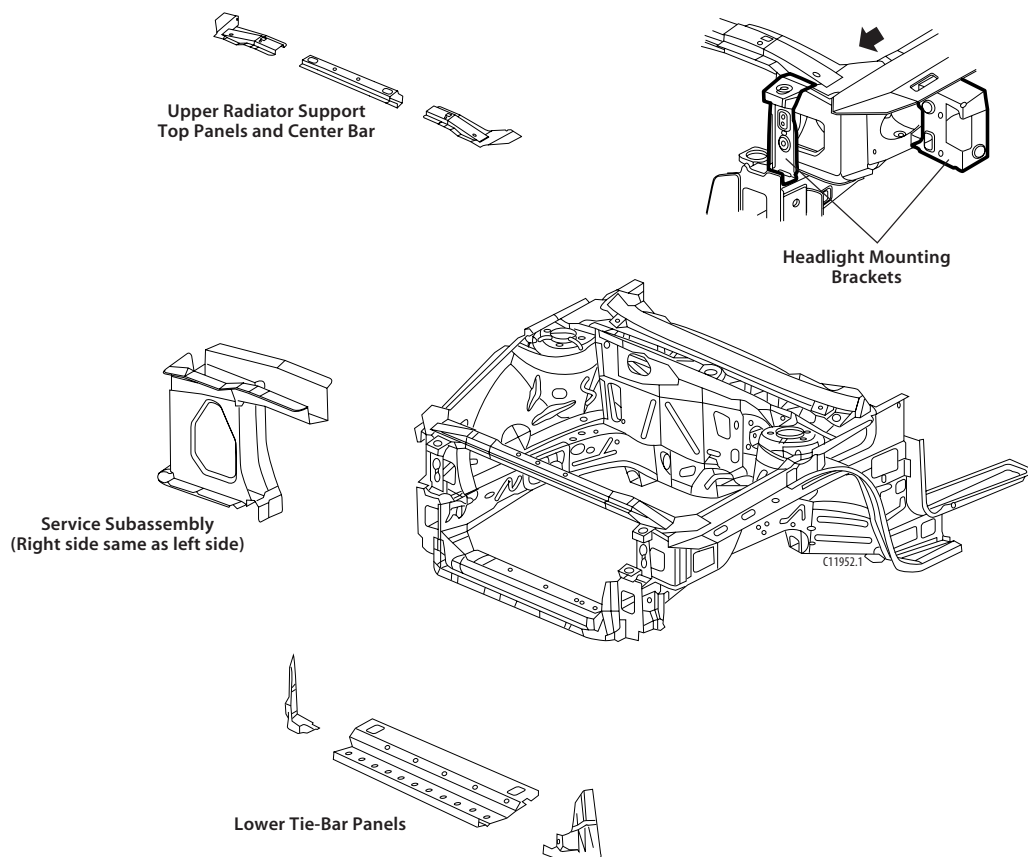

Figure 2-1:
Upper Radiator Support Assembly