

## SIR Disabling and Enabling Zone 2

### Disabling Procedure

1. Turn the steering wheel so that the vehicle's wheels are pointing straight ahead.
2. Place the ignition in the OFF position.
3. Remove the kick-up panel (2) to expose the instrument panel (I/P) fuse block.
4. Remove the I/P fuse block cover (1).

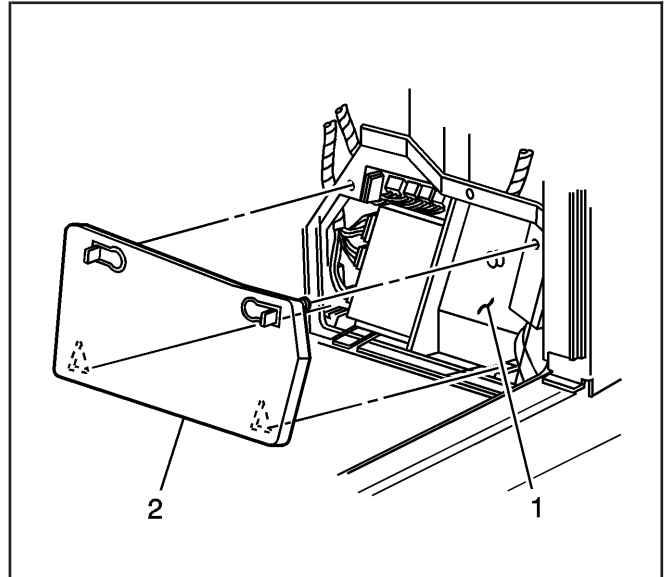

1246577

**Important:** With the SDM fuse removed and the ignition in the ON position, the AIR BAG warning indicator illuminates. This is normal operation, and does not indicate an SIR system malfunction.

5. Locate the SDM fuse within the I/P fuse block.
6. Remove the SDM fuse from the I/P fuse block.

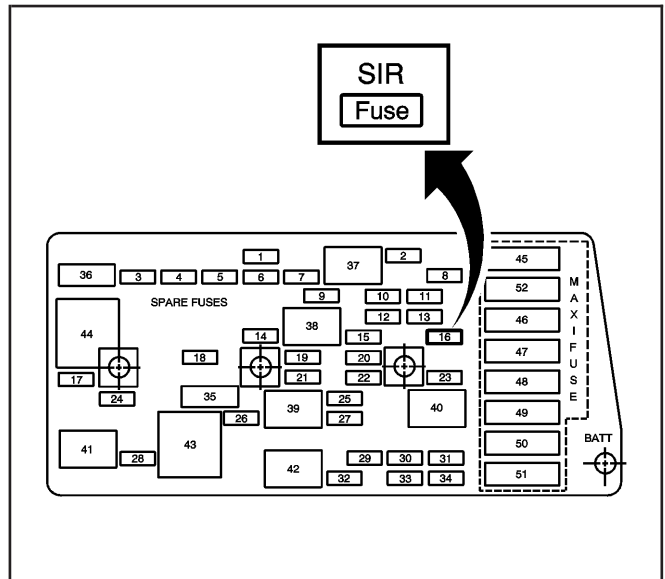

1246574

7. Open left/driver door and remove the door trim panel.
8. Locate left side impact sensor (SIS) (1).
9. Remove the connector position assurance (CPA) (3) from SIS connector (2).
10. Remove the SIS connector (2) from the SIS (1).

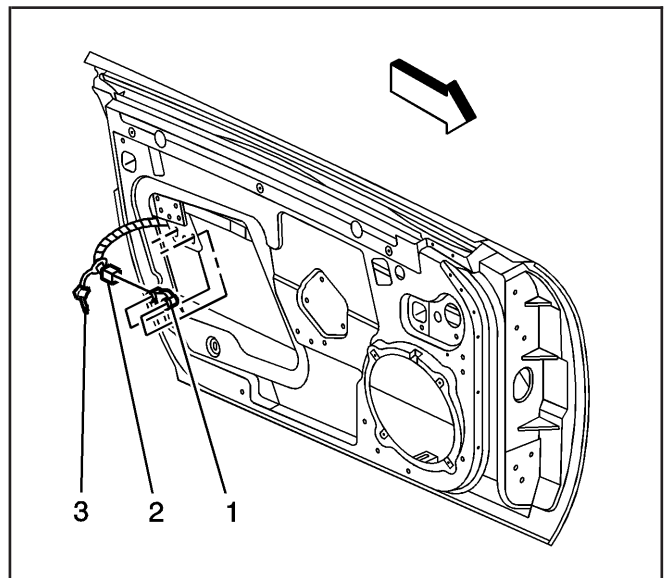

1246629

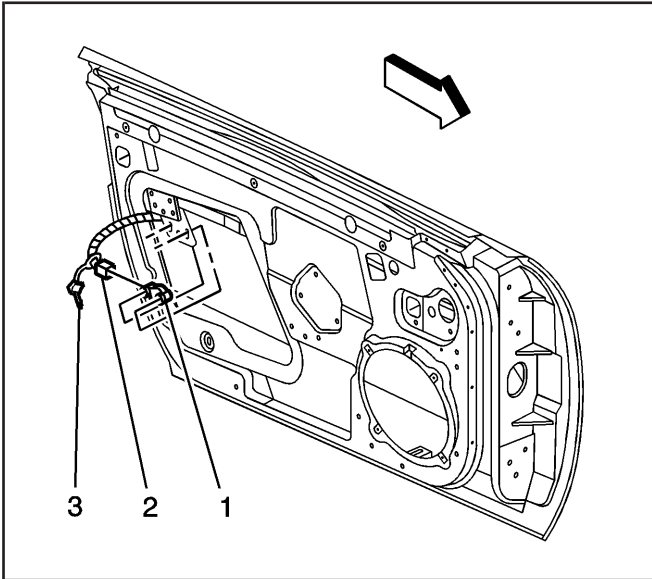

1246629

### Enabling Procedure

1. Place the ignition in the OFF position.
2. Connect the SIS connector (2) to the SIS (1).
3. Connect the CPA (3) to the SIS connector (2).
4. Install the door trim panel.

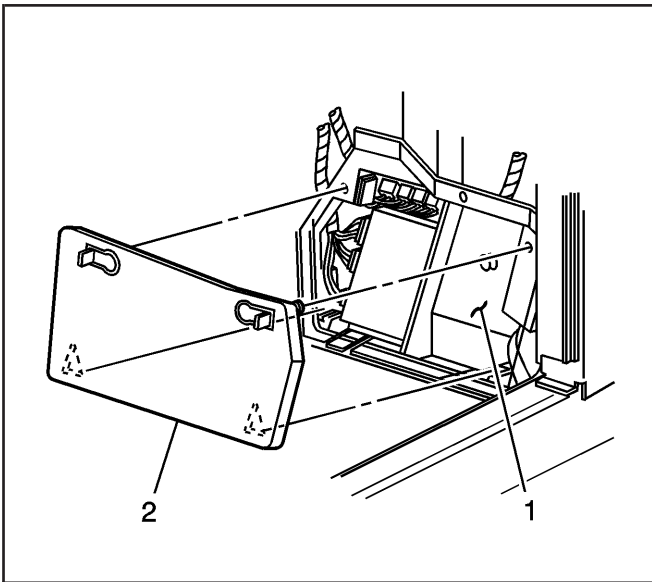

1246577

5. Install the SDM fuse into the I/P fuse block.
6. Install the I/P fuse block cover (1).
7. Install the kick-up panel (2) to cover the I/P fuse block (1).
8. Use caution while reaching in and place the ignition to the ON position.  
The AIR BAG indicator will flash then turn OFF.
9. Perform the Vehicle System Check if the AIR BAG warning indicator does not operate as described.