

Body Rear End Panel Replacement

Warning: Refer to [Collision Sectioning Warning](#) in the Preface section.

Warning: Refer to [Approved Equipment for Collision Repair Warning](#) in the Preface section.

Warning: Refer to [Glass and Sheet Metal Handling Warning](#) in the Preface section.

1. Disable the SIR system. Refer to [SIR Disabling and Enabling](#).
2. Disconnect the negative battery cable. Refer to [Battery Negative Cable Disconnection and Connection](#).
3. Remove all related panels and components.
4. Restore as much of the damage as possible to factory specifications using 3-dimensional measuring equipment.
5. Note the location and remove the sealers and anti-corrosion materials from the repair area, as necessary. Refer to [Anti-Corrosion Treatment and Repair](#).

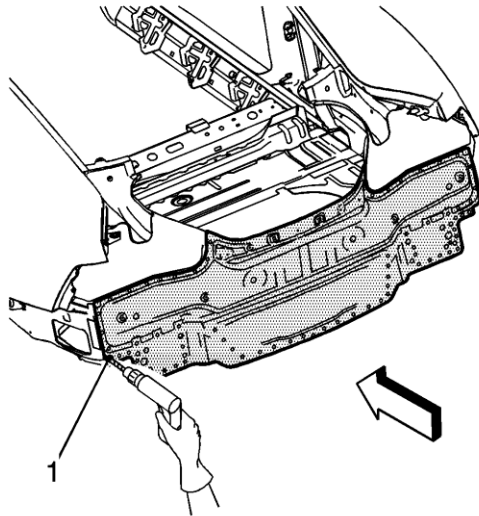

Note: Record the number and location of the original welds for installation of the service part.

6. Locate and drill out all factory welds (1).
7. Remove the damaged rear end panel (1).

Installation Panel

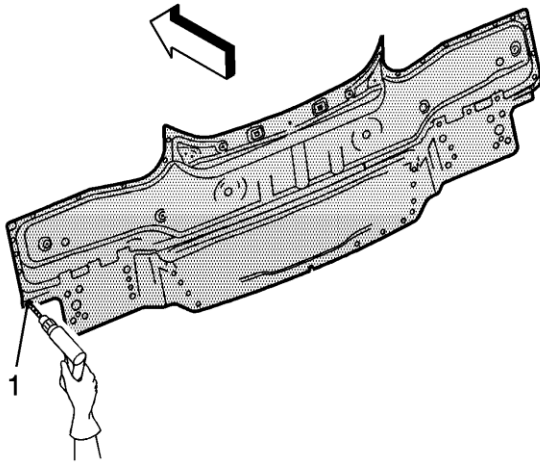

Note: If the location of the original plug welds cannot be determined or structural weld thru adhesive was present, space plug weld holes every 40 mm (1 1/2 in) apart.

1. Drill 8 mm (5/16 in) plug weld holes.
2. Prepare all attachment surfaces as necessary.
3. Apply GM approved Weld-Thru Coating or equivalent to all mating surfaces. Refer to [Anti-Corrosion Treatment and Repair](#).

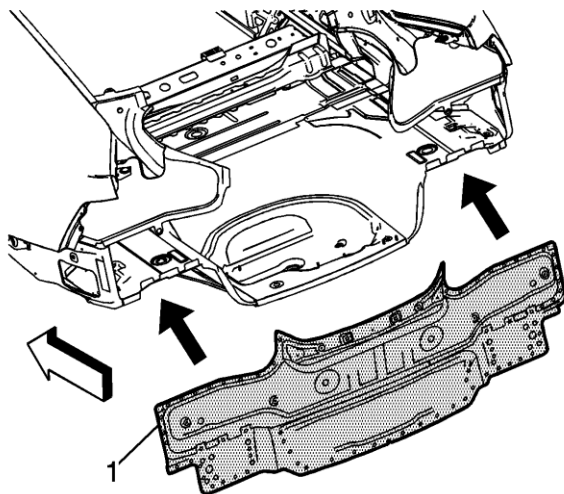

4. Position the rear end panel (1).
5. Clamp service parts in position.

6. Inspect the vehicle for proper dimensions using 3-dimensional equipment.

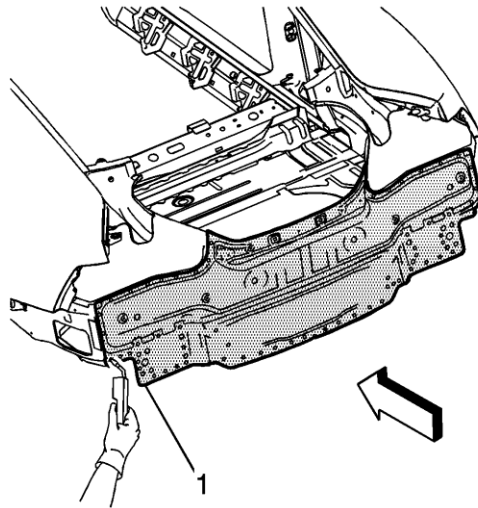

7. Plug weld accordingly (1).
8. Clean and prepare all welded surfaces.
9. Apply the sealers and anti-corrosion materials to the repair area, as necessary. Refer to [Anti-Corrosion Treatment and Repair](#).
10. Paint the repair area. Refer to [Basecoat/Clearcoat Paint Systems](#).
11. Install all related panels and components.
12. Connect the negative battery cable. Refer to [Battery Negative Cable Disconnection and Connection](#).
13. Enable the SIR system. Refer to [SIR Disabling and Enabling](#).

© 2009 General Motors Corporation. All rights reserved.