

Quarter Inner Panel Sectioning (Coupe)

Removal Procedure

Caution: Refer to [Approved Equipment for Collision Repair Caution](#) in Cautions and Notices.

Important: The quarter inner panel is replaced by sectioning the panel on to the vehicle and created from a complete body side inner panel service assembly.

1. Disable the SIR system. Refer to [SIR Disabling and Enabling](#) .
2. Disconnect the negative battery cable. Refer to [Battery Negative Cable Disconnection and Connection](#) .

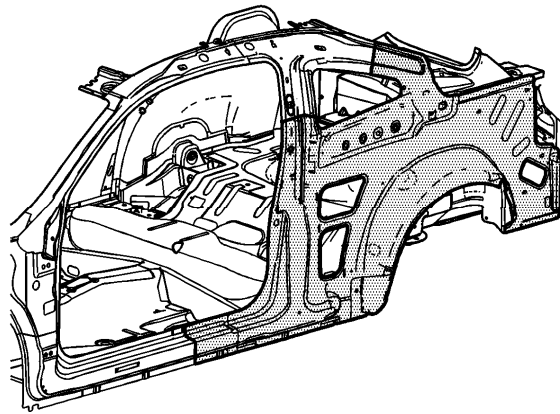

3. Remove all related panels and components.
4. Repair as much of the damage as possible. Refer to [Dimensions - Body](#) .
5. Note the location and remove the sealers and anti-corrosion materials from the repair area, as necessary. Refer to [Anti-Corrosion Treatment and Repair](#) .

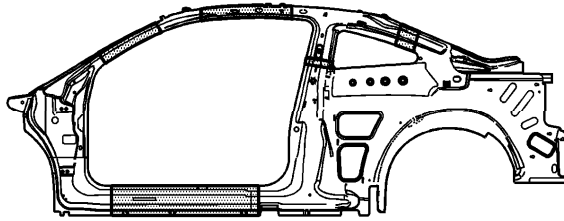

Important: Do not damage any inner panels or reinforcements.

6. Cut the panel in the locations where the sectioning is to be performed, within the zones shown.

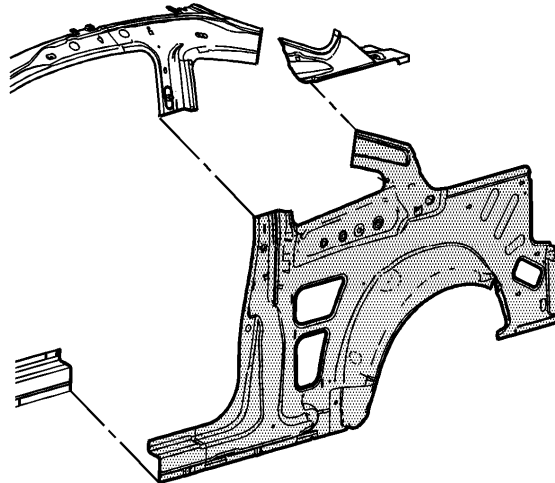

7. Locate and drill out all necessary factory welds within the areas of the quarter inner panel only. Note the number and location of the welds for installation of the inner quarter assembly.
8. Remove the damaged inner quarter assembly.

Installation Procedure

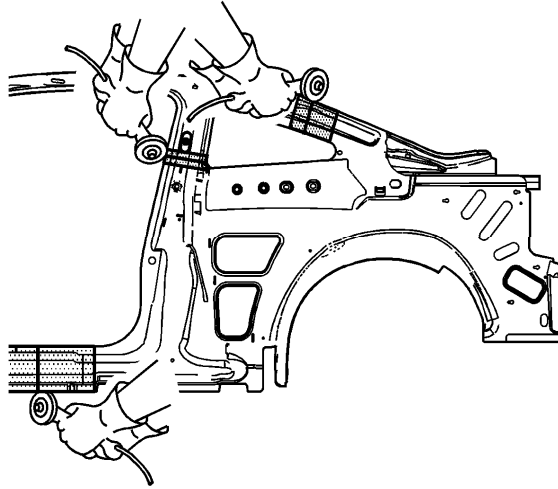

1. Cut the service panel in corresponding locations to fit the original panel. The sectioning joint should be trimmed to allow a gap of 1 1/2 times the metal thickness of the sectioning joint.
2. Create a 50-mm (2-in) backing plate for the sail panel area and create a 100-mm (4-in) backing plate for the rocker panel area from the unused portion of the service part. Trim the backing plate as necessary to fit behind the sectioning joint.

Important: In the B-pillar area, use overlap sectioning.

Important: If the location of the original plug weld holes cannot be determined, space the plug weld holes every 40 mm (1½ in) apart.

3. Drill 8-mm (5/16-in) plug weld holes in the service part as necessary in the corresponding locations noted on the original panel.
4. Prepare all mating surfaces as necessary.
5. Apply GM-approved Weld-Thru Coating or equivalent to all mating surfaces. Refer to [Anti-Corrosion Treatment and Repair](#) .

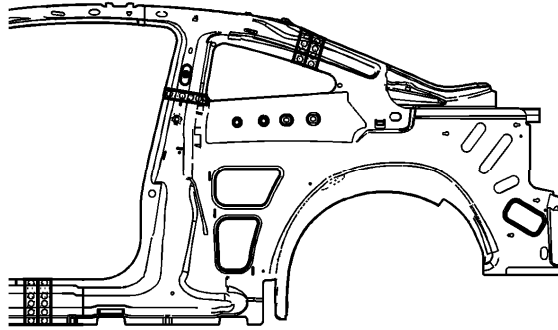

6. Position the inner quarter assembly to the vehicle. Clamp the assembly in place.
7. Plug weld accordingly.
8. Clean and prepare all of the welded surfaces.
9. Apply the sealers and anti-corrosion materials to the repair area, as necessary.
Refer to [Anti-Corrosion Treatment and Repair](#) .
10. Paint the repaired area. Refer to [Basecoat/Clearcoat Paint Systems](#) .
11. Install all related panels and components.
12. Connect the negative battery cable. Refer to [Battery Negative Cable Disconnection and Connection](#) .
13. Enable the SIR system. Refer to [SIR Disabling and Enabling](#) .