

# Door Frame Reinforce Sectioning - Center Pillar

## Removal Procedure

**Caution:** Refer to [Approved Equipment for Collision Repair Caution](#) in Cautions and Notices.

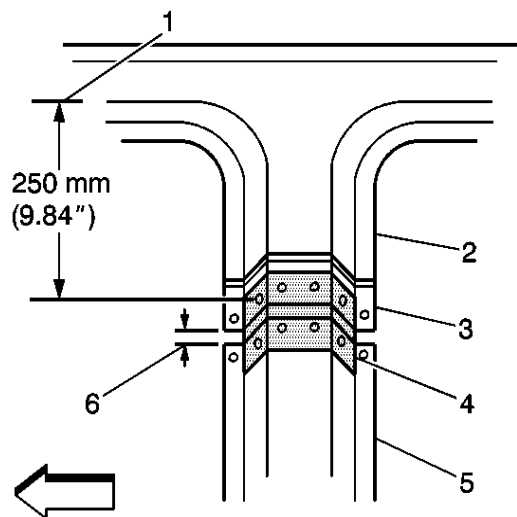

**Important:** The striker plate is mounted in a cage that allows some degree of adjustment independent of the outer panels position. Use body dimensions to ensure that the striker mounting location falls within the plates range of adjustment.

1. Remove all related panels and components.
2. Visually inspect and restore as much of the damage as possible.
3. Remove sealers and anti-corrosion materials as necessary.

**Important:** When sectioning both the inner (3) and the outer panels (2) this should result in a 100 mm (4 in) offset in the sectioning joints. Use care not to cut the inner door opening frame when cutting the center pillar reinforcement.

**Important:** Sectioning of the center pillar reinforcement should be performed only in the specified sectioning locations.

4. Cut the reinforcement (3) panel 250 mm (13 3/4 in) from the lower edge of the door opening (1).
5. Locate and mark all factory welds. Note the number and location of welds for installation of the service assembly.
6. Drill out all factory welds.

## Installation Procedure

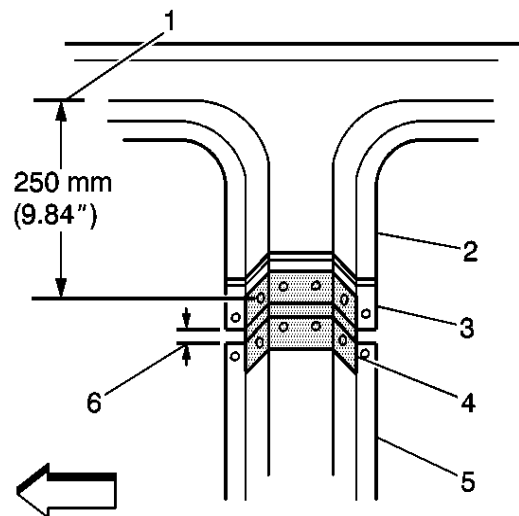

1. On the service part (5) mark a horizontal line to leave a gap of 1 1/2 times the thickness of the metal (6) at the sectioning joint.
2. Cut the service reinforcement panel along this line.
3. Cut a 50 mm (2 in) piece from the unused portion of the service part (5) for a backing plate.
4. Remove the flange on each side of the backing plate (4) so that it will fit behind the sectioning joint (6).
5. Drill 8 mm (5/16 in) holes for plug welding in the service part in the location noted from the original panel.

6. Drill holes for plug welding along the sectioning cuts on both the service part (5) and the original panel (3).
7. Locate these holes approximately 13 mm (1/2 in) from the edge of the sectioning cuts.
8. Prepare the mating surfaces as necessary. Position the backing plate with 25 mm (1 in) of the backing plate exposed. Position the service part (5) to overlap the exposed backing plate. Apply GM-approved Weld-Thru Coating or equivalent to all mating surfaces. Refer to [Anti-Corrosion Treatment and Repair](#).
9. Make 25 mm (1 in) welds along the seams with 25 mm (1 in) gaps between.
10. Go back and complete the stitch weld. This will create solid joint with minimal heat distortion.
11. Complete all other welds as necessary.
12. Clean and prepare welded surfaces.

**Important:** Prior to refinishing, refer to GM 4901MD-99 Refinish Manual for recommended products. Do not combine paint systems. Refer to paint manufacturer's recommendations.

13. Prime with 2 part catalyzed primer.
14. Apply sealers and anti-corrosion materials as necessary.