

Rail Sub-Assembly Replacement (Front Lower)

Removal Procedure

1. Remove all related panels and components.
2. Restore as much of the damage as possible to factory specifications.
3. Note the location and remove the following as necessary:
 - Anti-corrosion materials
 - Sound deadeners
 - Sealers
4. Separate the floor pan reinforcement (1) weld flanges from the inside of the lower rail. Care must be taken not to damage the weld flanges.

IMPORTANT: Do not damage any inner panels or reinforcements.
5. Locate and drill out all factory welds. Note the number and location of welds for installation of the Front Lower Rail.
6. Remove the damaged rail.

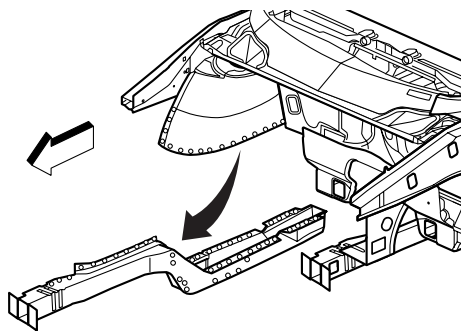
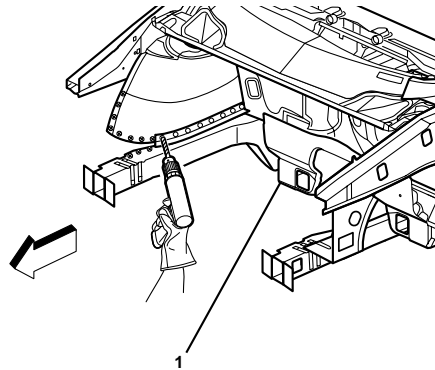
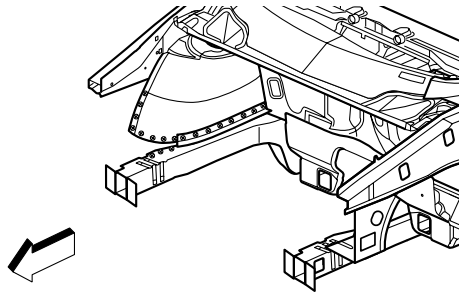

Rail Sub-Assembly Replacement (Front Lower)

Installation Procedure

1. Prepare the mating surfaces of the floor pan reinforcement (1).
2. Turn the weld flanges outward (2) to be welded to the front lower rail.

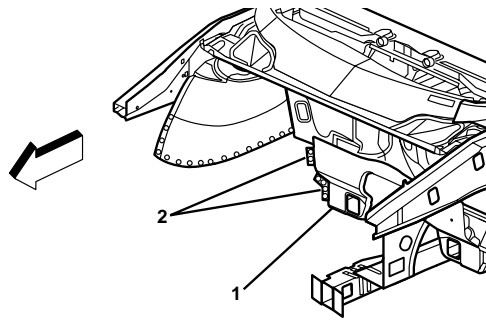

3. Drill 8 mm (5/16 in.) plug weld holes as necessary in locations noted from removal.

IMPORTANT: In any area damaged beyond recognition, space plug weld holes every 40 mm (1-1/2 in.) apart.

4. Drill 8 mm (5/16 in.) plug weld holes as necessary in locations noted from the original panel.
5. Prepare all attachment surfaces as necessary.
6. Apply weld-thru primer to all bare-metal surfaces.

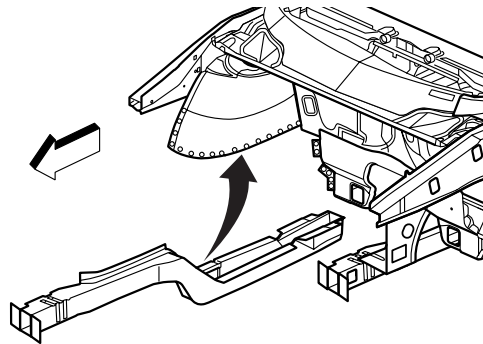

7. Position the service part
8. Plug weld accordingly.

IMPORTANT: Prior to refinishing, refer to publication GM4901M-D-01 GM Approved Refinish Materials for recommended products. Do not combine paint systems. Refer to paint manufacturer's recommendations.

9. Clean and prepare all welded surfaces.

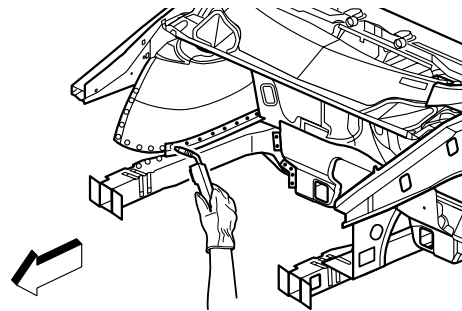

10. Apply the following as necessary :

- Anti-corrosion materials
- Sound deadeners
- Sealers

11. Refinish as necessary.
12. Install all related panels and components.

