

Door Frame Sectioning—Outer (Center Pillar)

Removal Procedure

1. Remove all related panels and components.
2. Restore as much of the damage as possible to factory specifications.
3. Note the location and remove the following as necessary:
 - Anti-corrosion materials
 - Sound deadeners (1)
 - Sealers

IMPORTANT: Do not damage any inner panels or reinforcements.

4. Cut the panel where sectioning is to be performed.

5. Locate and drill out all factory welds. Note the number and location of welds for installation of the service part.

6. Remove the damaged Center Pillar.

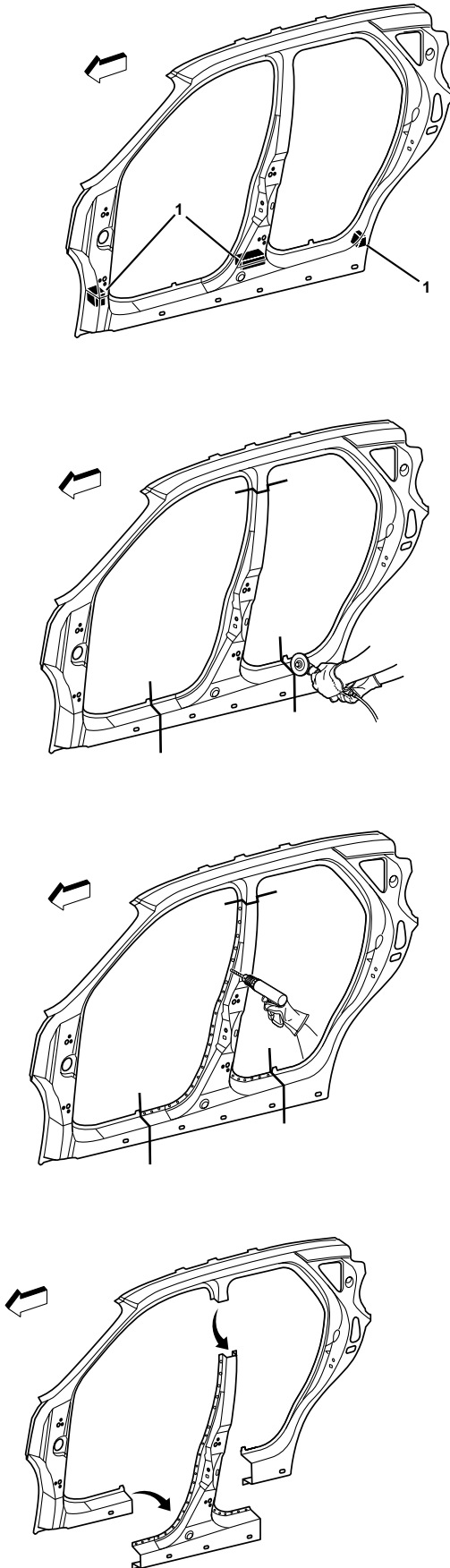

Door Frame Sectioning—Outer (Center Pillar)

Installation Procedure

1. Cut the replacement Center Pillar in corresponding locations to fit the remaining original panel. The sectioning joint should be trimmed to allow a gap of one-and-one-half times the metal (1) thickness at the sectioning joint.
2. In the Center Pillar, create a 50 mm (2 in.) backing plate (1) from the unused portion of the Door Frame Opening. Trim the backing plate as necessary to fit behind the sectioning joint.
3. In the rocker locations, create a 100 mm (4 in.) backing plate (2) from the unused portion of the door frame opening. Trim the backing plate as necessary to fit behind the sectioning joint.
4. Drill 8 mm (5/16 in.) plug weld holes along the sectioning cut on the remaining original part.

—continued

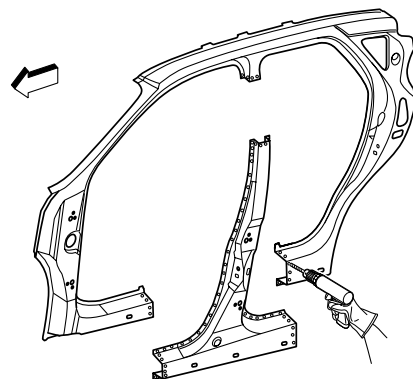
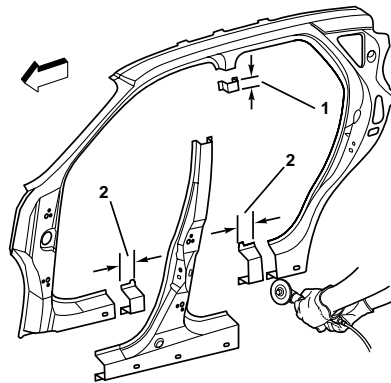
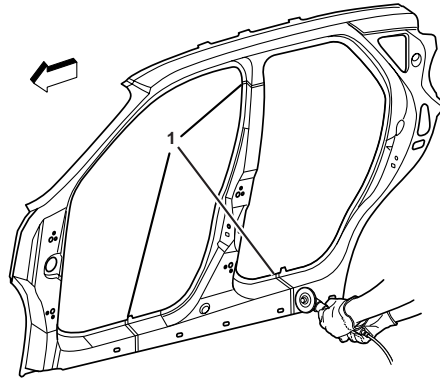

Door Frame Sectioning—Outer (Center Pillar) Installation Procedure con't

IMPORTANT: In any area damaged beyond recognition, space plug weld holes every 40 mm (1-1/2 in.) apart.

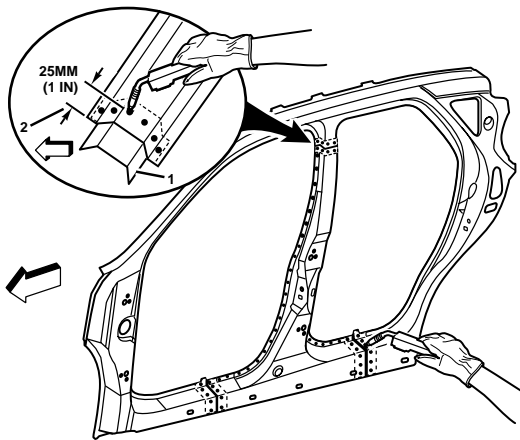

5. Drill 8 mm (5/16 in.) plug weld holes as necessary in locations noted from the original panel.
6. Prepare all attachment surfaces as necessary.
7. Apply weld-thru primer to all bare-metal surfaces.
8. Fit the backing plate (1) halfway into the sectioning joint (2) clamp and plug weld to the vehicle.
9. Align the Center Pillar using three-dimensional measuring equipment.
10. Plug weld accordingly.

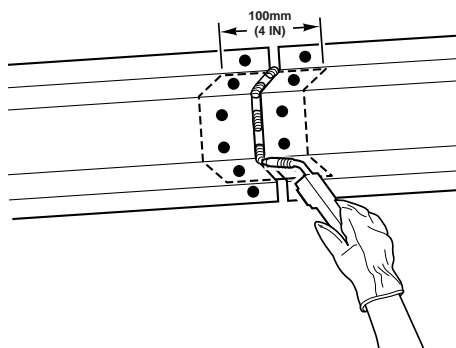

11. To create a solid weld with minimum heat distortion, make 25 mm (1 in.) stitch welds along the seam with 25 mm (1 in.) gaps between them. Then go back and complete the stitch weld

IMPORTANT: Prior to refinishing, refer to publication GM 4901M-D-01 GM Approved Refinish Materials for recommended products. Do not combine paint systems. Refer to paint manufacturer's recommendations.

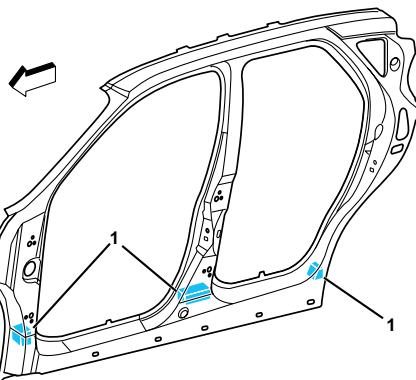

12. Clean and prepare all welded surfaces.
13. Apply the following as necessary:
 - Anti-corrosion materials
 - Sound deadeners (1)
 - Sealers
14. Refinish as necessary.
15. Install all related panels and components.