



Info - Expandable Acoustic Foam (Two Component Sound Dampener) Usage with Collision Damage Repairs #02-08-98-003 - (06/21/2002)

Subject:

**Models: 2003 and Prior Passenger Cars and Light Duty Trucks
2003 HUMMER H2**

When performing collision repairs or replacing some components on most GM model vehicles, it is important that the foam blocking material used for noise, water and dust control be replaced as well.

This foam material is packaged as a two component material. This material is applicable for replacement of the original production material, since both are a "closed cell material" and are not water absorbent.

TYPICAL LOCATIONS for this material are indicated on the illustrations below.

Two Component Material

This material has more of an industrial application, but can be obtained (from the sources listed below) in various quantities useful for collision repairs.

It is especially useful when filling "blind" areas (areas that can't be seen) that require the expansion of the material to ensure sealing.

Our experiments indicate the following information:

Important: Do not use more than was needed for production applications.

- Over application of this material in some areas of the vehicle may change performance characteristics and is not recommended.
- It is recommended that a small amount be applied into a disposable container to become familiar with the rate of discharge and ensure proper mixing of both material parts.

Contact the following sources for information on sales and distribution.

- For larger jobs (rocker box):
 - *"FROTH PAK" 12 KIT, Insta-Foam Products, Inc., Disturbed by Essex Arg.
 - Contact 1-800-246-4405, ext.11, (in Canada, contact Dow Chemicals at 1-800-366-4740).
- For smaller jobs (A pillar):
 - *3M® Corporation, Flexible Foam 0.201L (6.8 oz), P/N 8463.
 - In U.S., call 1-800-521-8100, ext 5165 (in Canada, 1-800-364-3577).
 - *Kent Automotive, Urefoam Expandable 0.050L (1.7 oz), P/N 10630, or 0.296L (10 oz), P/N 10601.
 - In U.S., call 1-800-654-6333 (in Canada, 1-800-563-1717).

*We believe these sources and their products to be reliable. There may be additional manufacturers of such products. General Motors does not endorse, indicate any preference for or assume any responsibility for the products or equipment from these firms or for any such items which may be available from other sources.

Important: As always, follow the manufacturer's recommendations for application and safety.

Typical Foam Installation Areas (Cars)

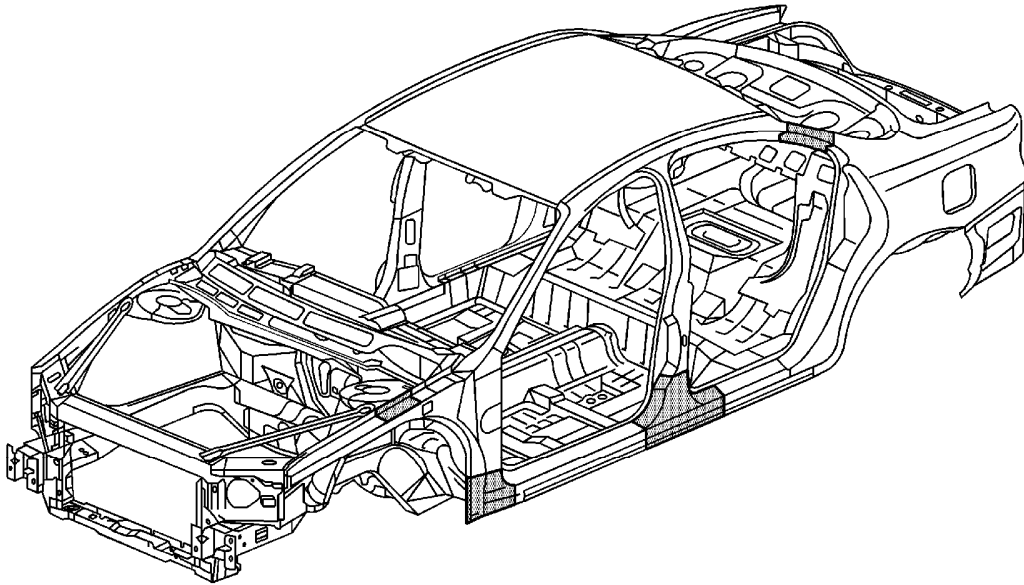

Typical Foam Installation Areas (Trucks)

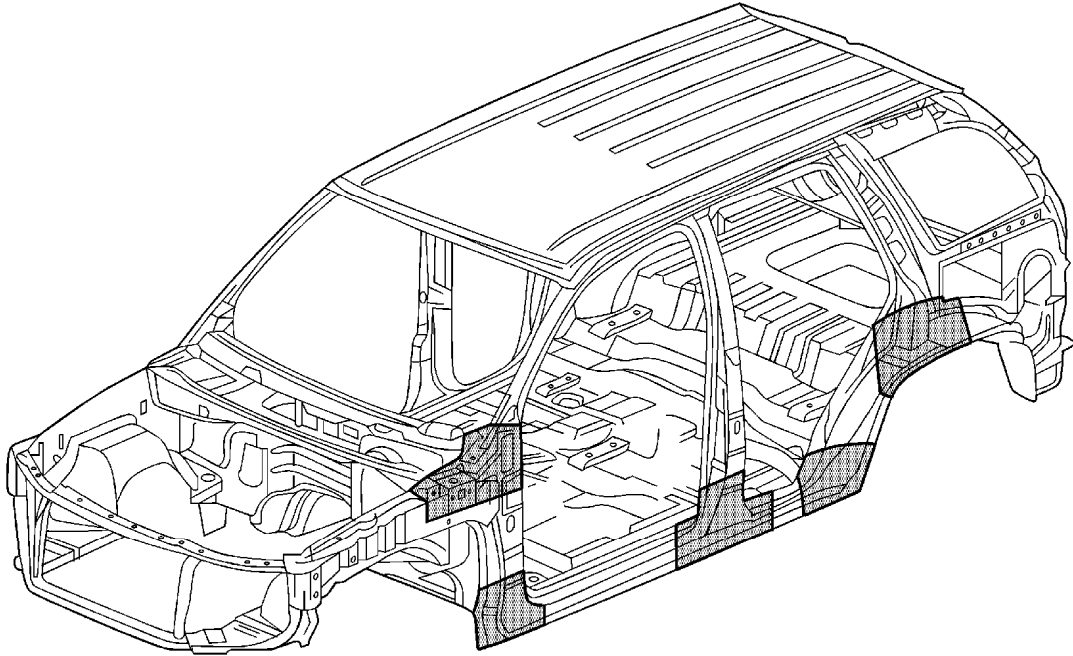

GM bulletins are intended for use by professional technicians, NOT a "do-it-yourselfer". They are written to inform these technicians of conditions that may occur on some vehicles, or to provide information that could assist in the proper service of a vehicle. Properly trained technicians have the equipment, tools, safety instructions, and know-how to do a job properly and safely. If a condition is described, DO NOT assume that the bulletin applies to your vehicle, or that your vehicle will have that condition. See your GM dealer for information on whether your vehicle may benefit from the information.



WE SUPPORT
VOLUNTARY
TECHNICIAN
CERTIFICATION

© Copyright General Motors Corporation. All Rights Reserved.